

Iwata-Medea, Inc. • P.O. Box 14397 • Portland, Oregon 97293
tel: (503) 253-7308 • fax: (503) 253-0721 • info@medea-artool.com

— WWW.IWATAAIRBRUSH.COM —



KUSTOM SERIES MANUAL & PARTS GUIDE

Hi-Line TH

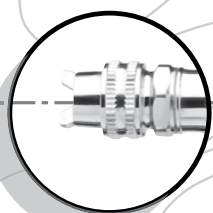

Revolution TR



Micron CM



Hi-Line CH

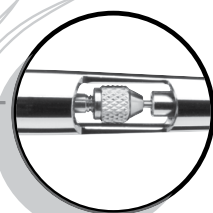

Eclipse CS

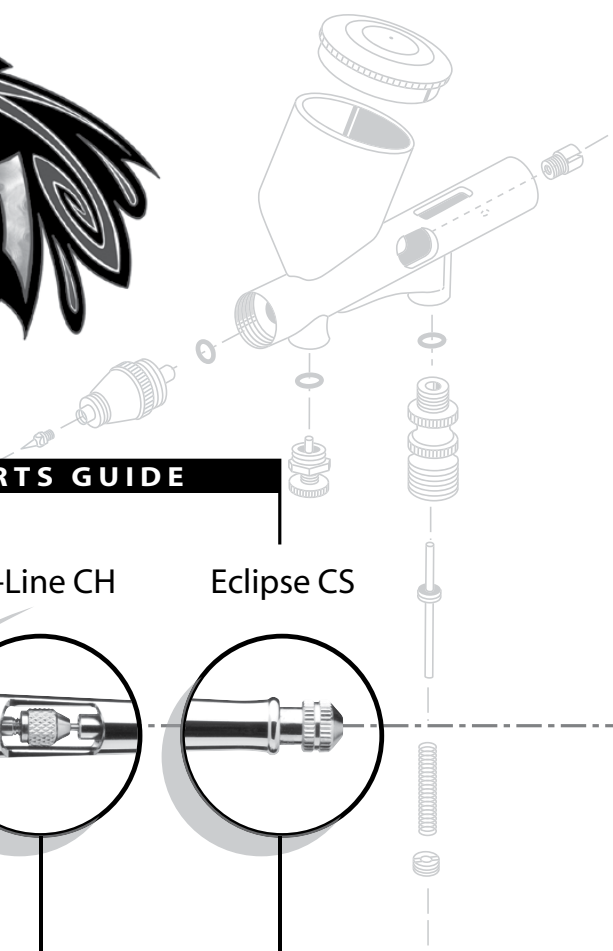
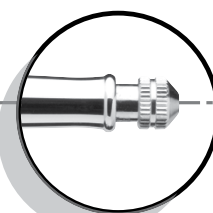

Congratulations on the purchase of your Iwata *Kustom*[™]— a versatile, reliable and high performance airbrush! *Kustom* painting takes pole position with the new Iwata *Kustom* airbrush series that sports large cups and shines in atomizing solvent-based paints.

**TEFLON PACKINGS • LARGE CUPS
PRE-SET HANDLES & TALL TRIGGERS**

distinguish these airbrushes as Kustom!



ONLY FROM IWATA-MEDEA

Iwata airbrushes are designed for the demanding professional. Modern, precision machining and carefully selected materials are employed in the manufacturing process to ensure consistent high performance and long life. Each Iwata airbrush is spray-tested before shipment to assure maximum performance and adherence to Iwata's strict quality standards. To maintain your Iwata *Kustom* airbrush at its peak performance, proper care and attention must be observed.

Iwata Kustom Hi-Line TH Airbrush

The first airbrush to create both round-pattern and fan-pattern sprays, the Kustom Hi-Line TH stands alone among its peers. Triggering the imagination of auto-body touch-up and Kustom painters, the Kustom TH delivers unprecedented fan pattern control with a minimum of overspray — giving it a unique advantage over mini touch up guns.

The fan-pattern air cap produces an oval spray pattern — perfect for creating smoother blends, gradations and backgrounds because the paint is atomized more consistently across the entire width of the spray. Great for small areas such as chip repair, fender wells, door jams and other hard-to-reach areas.

The Kustom TH also features an interchangeable round-pattern air cap, producing a round spray pattern with concentrated spray at its center, which is preferable for freehand graphics and fine line detail.

These features, and more, distinguish the Kustom TH as the ultimate airbrush for creative versatility.

K9200 Features:

Unique high-precision fan-pattern spray-head system;

- "Fan-Pattern" air cap (requires 1 HP or larger compressor)
- "Round-Pattern" air cap

TH Spray Patterns

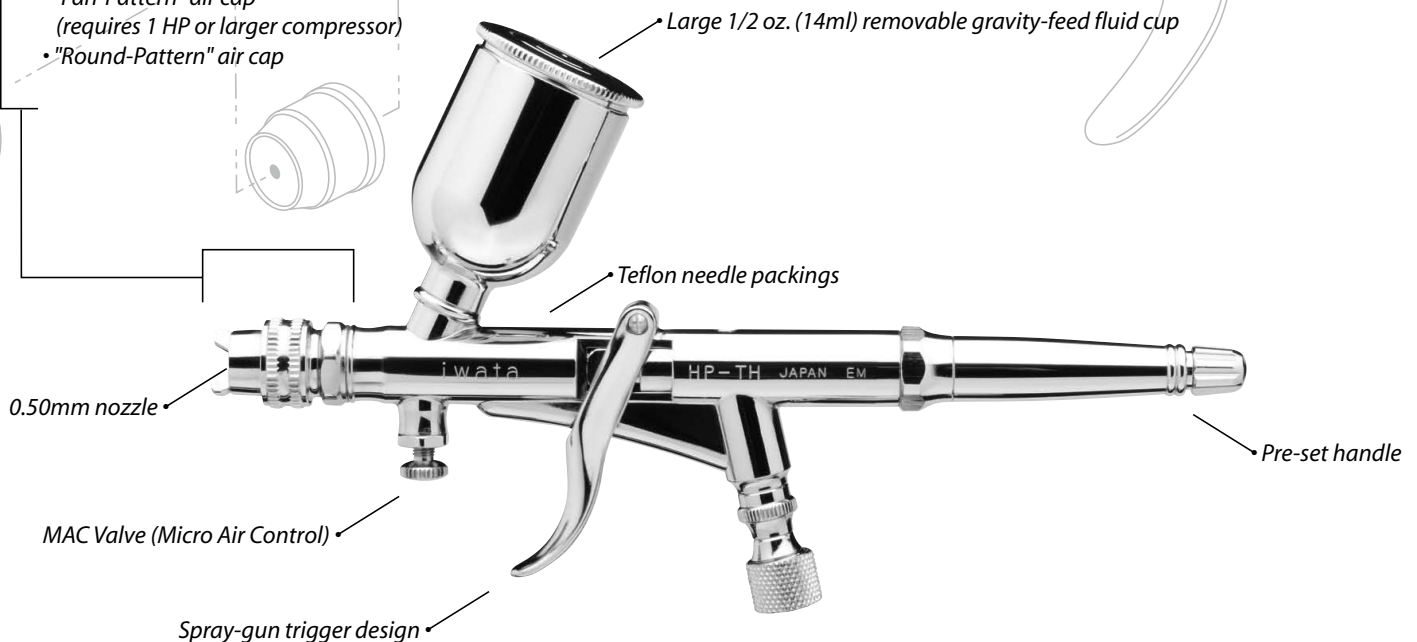

• Pistol-Grip Filter included - see page 15



Iwata Kustom Revolution TR Airbrush

Triggering the passion of spray-gun users, the Kustom Revolution TR airbrush proves easy to use. The long trigger provides commanding control of the airbrush spray.

K9400 Features:

- 0.30mm nozzle
- Teflon needle packings
- Large 3/4 oz. (21ml) gravity fluid removable cup
- Spray-gun trigger design
- Pre-set handle
- Pistol-Grip Filter included - see page 15



Iwata Kustom Micron CM Airbrush

The MAC Daddy of all airbrushes, the Kustom Micron CM is framed around the Iwata Custom Micron airbrush. The new Kustom Micron CM airbrush provides extreme control of ultra fine-line spray, silky-smooth atomization and ultimate paint-flow control with hand-tuned, hand-adjusted performance. Iwata Micron airbrushes are world-renown as the professional's choice for the utmost of fine line detail.

K9000 Features:

- 0.23mm "Matched Head System"
- Teflon needle packings
- Large 1/2 oz. (14ml) gravity fluid cup
- Taller trigger for extreme control of trigger action and paint flow
- Pre-set handle
- MAC valve for precise air pressure control
- Pistol-Grip Filter included - see page 15



Iwata Kustom Hi-Line CH Airbrush

A preferred airbrush for users who need ultimate control of fine-line work and medium background spraying, the Kustom Hi-Line CH boasts a MAC valve that supplies precise air control to the head of the airbrush for ultimate control.

K9100 Features:

- 0.30mm nozzle
- Teflon needle packings
- Large 1/2 oz. (14ml) gravity fluid cup
- Taller trigger for extreme control of trigger action and paint flow
- Pre-set handle
- MAC Valve for precise air-pressure control
- Pistol-Grip Filter included - see page 15



Iwata Kustom Eclipse CS Airbrush

The workhorse of the Kustom line, the Kustom Eclipse CS features a large general-purpose nozzle/needle combination. Still maintaining fine-line control, the Kustom Eclipse CS creates wide background sprays with fine atomization and control. Designed to spray metallic, pearlescent and base coat paints.

K9300 Features:

- 0.35mm nozzle
- Teflon needle packings
- Large 1/2 oz. (14ml) gravity fluid cup
- Taller trigger for extreme control of trigger action and paint flow
- Pre-set handle
- Pistol-Grip Filter included - see page 15

— GETTING STARTED —

Compressor

Choose an appropriate compressor for your Kustom airbrush. The Iwata Sprint Jet or Smart Jet compressors are a good beginner's choice and will provide approximately 25 - 30 psi of air pressure to your Kustom TR, CM, CH and CS airbrushes. The high powered Iwata Power Jet Pro, Power Jet and Power Jet Lite compressors can be controlled to provide 5 - 45 psi to your Kustom airbrush, and are the ideal air sources to utilize all of the Kustom airbrush series' unique potential.

PLEASE NOTE: The TH fan pattern air cap requires a 1 HP or larger compressor.

Assembly and Spray Test

Carefully screw the Pistol-Grip Filter (#40) onto the air valve of your Kustom airbrush and hand tighten. Next, screw air hose to bottom of the Pistol-Grip Filter and hand tighten. CAUTION: Be especially careful to not cross-thread or over-tighten connections or you may damage the filter. Finally, screw the air hose onto the compressor and lightly tighten with a wrench. DO NOT OVERTIGHTEN!

Check to ensure that you can pull the main lever (#14 on CM, CH and CS) or trigger (#14 on TH and TR) fully back. If trigger action is limited, unscrew the adjusting knob at the back end of the pre-set handle (#39) to allow the main lever (or trigger) to be fully pulled back, or adjust as needed.

Turn the compressor on, and if using an Iwata Power Jet Pro, Power Jet or Power Jet Lite compressor, adjust the pressure to 25 psi. Check for any air leaks at air hose connections.

If your airbrush is equipped with a Micro Air Control (MAC) valve (#16 on TH, CM and CH), adjust valve to wide open position, allowing air to flow when the main lever is pushed down, or trigger is pulled back.

Pointing the airbrush away from you, press down on the main lever (or pull trigger) to start the flow of air through the airbrush and clear it of any residue. To further ensure a clean airbrush, add a small amount of the appropriate cleaner or solvent into the color cup and spray it through the airbrush by pushing down and pulling back on the main lever (or pull trigger) to open the nozzle (#6) of the airbrush. Fully allow the all the cleaner to spray through the airbrush. CAUTION: Check paint manufacturer's label for details. Not all paints and cleaners are compatible with one another, and the appropriate cleaner must be used to ensure that your airbrush is properly maintained.

CAUTION: Always wear appropriate respirator or spray mask and protective clothing. Spray in a well ventilated area.

— GENERAL OPERATION —

Fine Line Spray

To spray a fine line, depress and pull the main lever (#14 on CM, CH and CS) or pull trigger (#14 on TH and TR) back slightly while positioning the airbrush close to the surface (approximately 1/16 - 1/2 inch). The thickness of the line can be controlled by varying the distance of the airbrush from the surface and adjusting the amount of paint flow by the position of the main lever (or trigger).

Wide Line and Background Spraying

For wider lines and background spray, depress and pull the main lever (or pull trigger) further back to release more paint. Increase the distance between the airbrush and surface (from 1/2 - 6 inches is common) to control spray width. Increasing the air pressure will also affect the spray width. Kustom airbrushes will spray a background width of approximately 2" (TR, CM, CH and CS) to 4" (TH).

The TH is equipped with a fan air cap (#5A) creating an oval spray pattern, as opposed to a circle. The fan air cap produces a superior spray pattern for backgrounds, smoother blends and gradations. To use the fan air cap, loosen the cover ring (#4) and position the tabs on the fan air cap up-and-down for a horizontal spray pattern, and side-to-side for a vertical spray pattern. The round pattern air cap (#5B) can be substituted to create a circle spray pattern for finer detail work.

Cutaway Handle

The cutaway handle (#39) is a special feature on the Kustom TR, CM, CH and CS. Its purpose is two-fold;

- 1) A wider background spray pattern can be accomplished by pulling the exposed needle chucking nut (#37) back to fully open the nozzle, while simultaneously depressing the main lever (#14 on CM, CH and CS) or trigger (#14 on TR), passing more paint through the nozzle.

- 2) Free up paint clogs that may have formed at the tip of the airbrush by pulling the exposed needle chucking nut back to fully open the nozzle while simultaneously depressing the main lever or trigger, allowing the clog to be sprayed out.

Stippling

Iwata Kustom TR, CM, CH and CS airbrushes are designed to produce a wide range of stippling textures. Stippling is achieved by removing the needle cap (#1) and nozzle cap (#2) and adjusting the air pressure between 5 and 50 psi. Lower air pressure will give you coarse stipple whereas a higher pressure will provide a fine stipple effect. Paint viscosity will also affect the stippling texture. At low air pressure the main lever (or trigger) may need to be pumped to create a coarse stipple.

Air Pressure

Working pressures vary from between 10 to 45 psi, depending on what type of work is being done and what textures are desired. The viscosity of the paint and your desired spray characteristics will also have an effect on which pressure is ideal. As a general rule, larger amounts of paint or thicker paints will be sprayed with higher pressures.

Paint Preparation

Proper preparation and filtering the paint through a nylon mesh is recommended for best performance. Paint should be thinned with its proper solvent. It is best to prepare the paint relatively thin and make repeated passes across the work to achieve the desired shade. This will also improve the quality of your work and decrease the cleaning time of your airbrush.

Before Each Session

At the beginning of each session, spray water or appropriate paint solvent through the airbrush to make sure the airbrush is working properly.

Cleaning the Airbrush Between Color Changes

Remove excess paint left in the color cup (or center cup - #11 on TH & TR) of your airbrush. Rinse the color cup with airbrush cleaner and use a paper towel to wipe out any remaining paint. Fill the bottom of the color cup with cleaner and spray it through until the spray is colorless. Remove excess cleaner. Now you are ready to use another color in the airbrush. When finished, repeat the cleaning procedure.

To Clean the Needle

Remove the pre-set handle (#39). Loosen the needle chucking nut (#37) and slowly pull the needle (#36) straight out. Wipe the residue off the needle by gently rotating it in a soft cloth folded over the needle. Carefully re-insert the needle into the airbrush and push gently until it seats against the nozzle. CAUTION: The most probable time to damage the needle is when the needle passes through the needle chucking guide (#31) and needle packaging screw (#27). If the needle stops abruptly, retract and examine the trigger mechanism for proper assembly and re-insert the needle again. Tighten the needle chucking nut.

After Each Session

At the end of an airbrush session, increase the air pressure and spray cleaning solution through the airbrush for a short period

of time. Remove and clean needle (refer to "To Clean the Needle" section).

Periodically

To ensure smooth trigger action, lubricate the needle (#36) and main lever mechanism (#14 on CM, CH and CS) or trigger (#14 on TR and TH) regularly. Lubricate slide cam (#28) on Kustom TH and TR airbrushes. Periodically, remove the needle and coat it with a high-quality lubricant (like Medea Super Lube); then wipe the needle with a soft, clean cloth, leaving on a light coat of lube. Re-insert the needle into the airbrush and re-tighten the needle chucking nut (#37). A couple drops of Super Lube can also be placed into the main lever slot or slide cam slot in the airbrush body to lubricate these moving parts.

NOTE: DO NOT over-lube the needle (#36) or the main lever mechanism (#14 on CM, CH and CS) or trigger (#14 on TR and TH) since it is possible to transfer the excess lube into the nozzle (#6), causing severe paint flow problems. DO NOT use light machine oil for lubrication. This will cause the needle to stick as it moves through the needle packing.

CAUTION: If it becomes absolutely necessary to dismantle the airbrush, please note the following: DO NOT use pliers to assemble or disassemble the airbrush. In most situations, you do not need tools to dismantle the airbrush. If needed, use an appropriate wrench to unscrew the head cap (#3 on CS) or head base (#7 on TH) which is the part that seals the nozzle onto specific airbrush bodies.

— TROUBLESHOOTING — *Troubleshooting Procedures***Skipping:**

- Dirty airbrush
 - Refer to Maintenance section
- Pigment too thick
- Air pressure too high
- Improper nozzle / body connection
- Loose head cap on CS
- Cracked or damaged nozzle (#6)
- Dried paint on tip of needle
 - Refer to Maintenance section

Double Line:

- Dirty airbrush
 - Refer to Maintenance section
- Bent needle
- Debris on tip of nozzle (#6) or in nozzle cap (#2)
- Cracked or damaged nozzle (#6)
- Dried paint on tip of needle (#36)
 - Refer to Maintenance section

Spattering:

- Dirty airbrush
 - Refer to Maintenance section
- Pigment build-up in needle cap (#1) or air cap (#5A or #5B on TH)
- Pigment too thick
- Air pressure too low
- Dried paint on tip of needle
 - Refer to Maintenance section

No Spraying:

- Clogged nozzle
 - Refer to Maintenance section
- Loose nozzle cap (#2 on TR, CM, CH and CS) - hand tighten only
- Loose head cap (#3 on CS) - tighten lightly with provided wrench
- Loose needle chucking nut (#37)
- Improper air pressure
- Paint too thick
- Cracked or damaged nozzle (#6)
 - Refer to Maintenance section
- Vent hole in cup lid is plugged

Bubbling in fluid cup or bottle:

- Loose nozzle cap (#2 on TR, CM, CH, CS) or head cap (#3 on CS) - hand tighten only
- Improper nozzle/body seal
- Cracked or damaged nozzle (#6)
 - Refer to Maintenance section

Trigger sticks or does not move smoothly:

- Use Medea Super Lube around the air valve piston packing o-ring (#17) and/or in the main lever (#14 on CM, CH and CS) or trigger (#14 on TR and TH) or slide cam (#28 on TR and TH)
 - Refer to Maintenance section



Nozzle #6

In time, the nozzle may wear or be damaged and may need to be replaced. Before replacing the nozzle, you need to pull the needle (#36) tip back into the airbrush protecting it from damage. Do this by removing the pre-set handle (#39), loosening the needle chucking nut (#37), and gently pulling the needle back away from the nozzle 3/4" to 1" from its seated position. Lightly tighten chucking nut (#37) to secure needle.

Nozzle — Kustom Hi-Line TH

Remove the cover ring (#4) and air cap (#5A or #5B), and remove the nozzle (#6) using the provided spanner wrench (#45). Lightly screw in new nozzle and tighten "lightly" with spanner wrench. DO NOT OVERTIGHTEN!

Replace the cover ring and tighten by hand. Re-seat the needle into the nozzle by loosening the needle chucking nut (#37) and gently pushing the needle forward until it seats with the new nozzle. Re-tighten the needle chucking nut and re-assemble the rest of the airbrush. NOTE: To ensure even wear, it is recommended that the needle be changed at the same time.

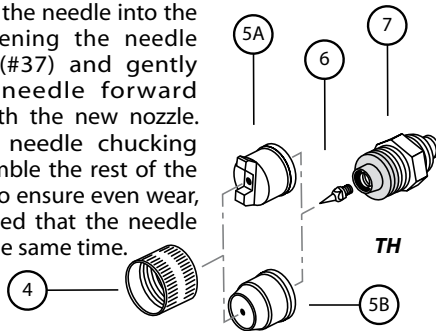
**Head System on Kustom Micron CM #9**

In time, components of the Kustom Micron CM Head System may wear or become damaged and may need to be replaced. The Head System is replaceable as a complete set and includes; needle cap (#1), nozzle cap (#2), fluid nozzle (#6), and head system base (#7). Before replacing the Head System, you need to pull the needle tip back into the airbrush protecting it from damage. Do this by removing the handle (#39), loosening the needle chucking nut (#37), and gently pulling the needle (#36) back away from the nozzle 3/4" to 1" from its seated position. Lightly tighten chucking nut to secure needle. Simply unscrew the entire Head System (#9) from the airbrush body and replace it with the new head system - tighten by hand. DO NOT OVERTIGHTEN! Re-seat the needle into the nozzle by loosening the needle chucking nut and gently pushing the needle forward until it seats with the new nozzle. Re-tighten the needle chucking nut and re-assemble the rest of the airbrush. NOTE: To ensure even wear, it is recommended that the needle be changed at the same time.

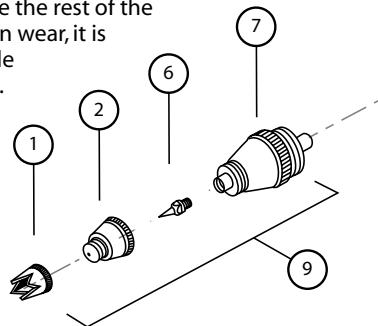
**Nozzle — Kustom Eclipse CS**

Use the provided spanner head cap wrench (#46) to unscrew the head cap (#3). If the nozzle (#6) is stuck, slightly push the side of the nozzle with your thumb, which should loosen it. Pull the nozzle out of the body of the airbrush and replace it with a new nozzle. Replace the head cap and "lightly" tighten with the provided head cap wrench. DO NOT OVERTIGHTEN! Re-seat the needle into the nozzle by loosening the needle chucking nut and gently pushing the needle forward until it seats with the new nozzle. Re-tighten the needle chucking nut and re-assemble the rest of the airbrush. NOTE: To ensure even wear, it is recommended that the needle be changed at the same time.

6

CS

**Nozzle — Kustom Revolution TR and Hi-Line CH**

Remove the nozzle cap (#2), and remove the nozzle (#6) using the provided spanner wrench (#45). Lightly screw in new nozzle and tighten "lightly" with spanner wrench. DO NOT OVERTIGHTEN! Re-seat the needle into the nozzle by loosening the needle chucking nut (#37) and gently pushing the needle forward until it seats with the new nozzle. Re-tighten the needle chucking nut and re-assemble the rest of the airbrush. NOTE: To ensure even wear, it is recommended that the needle be changed at the same time.

6

TR
CH**Needle #36**

Iwata needles are made of precision ground and hardened stainless-steel and will withstand prolonged usage. They are, however, subject to easy physical damage because of their very long taper and extremely fine tip. If the needle point becomes severely bent, it must be straightened before being pulled back through the nozzle. If not, the bent needle might damage the nozzle as it is pulled through.

Crown Cap on Kustom Micron CM #1

A crown cap is used to protect the needle when spraying a fine line and to prevent pigment build-up and spattering when spraying large backgrounds.

Pre-Set Handle #39

A threaded adjusting screw on the back of the handle limits the amount of the main lever (#14) or trigger (#14) pull back movement providing accurate control of the paint being sprayed.

Quick Disconnect (Optional Accessory)

A quick disconnect joint is screwed onto the airhose and a quick disconnect adaptor is screwed onto each airbrush. The quick disconnect joint on the airhose is used to facilitate fast changing of the airhose from one airbrush to another when using multiple airbrushes with one airhose.

All Iwata airbrushes are *Warranted* against all manufacturing defects of material and manufacture or workmanship for a period of FIVE years from date of purchase. This warranty does not cover fluid needles or fluid nozzles since these parts need to be replaced occasionally due to normal wear. Any other parts or materials that are or become defective so as not to be usable within this period will be repaired or replaced. This warranty does not cover damage caused by negligence or airbrushes which have been altered or abused in any way. Call or e-mail Iwata-Medea before returning an airbrush for the appropriate procedure for warranty repairs.



Copyright © 2006 Iwata-Medea Inc. All rights reserved. The Iwata-Medea logo, Iwata-Medea®, Iwata Eclipse™, Iwata Revolution™, Iwata Kustom™, Iwata Micron™, Sprint Jet™, Smart Jet™, Power Jet Pro™, Power Jet™, Power Jet Lite™, Medea Super Lube™, Pistol Grip Filter™, and all products denoted with ® or ™ are registered trademarks or trademarks of Iwata-Medea Inc. • Iwata® and the Iwata logo are registered trademarks of Anest Iwata Japan • Teflon® is a registered trademark of E.I. du Pont de Nemours and Company or its affiliates. All other trademarks are of their respective owners. For more information visit iwata-medea.com

Kustom™ logo design by Craig Fraser, Air Syndicate — online at GotPaint.com • Illustration and design by A.D. Cook dba ADCook Inc. — online at ADCook.com

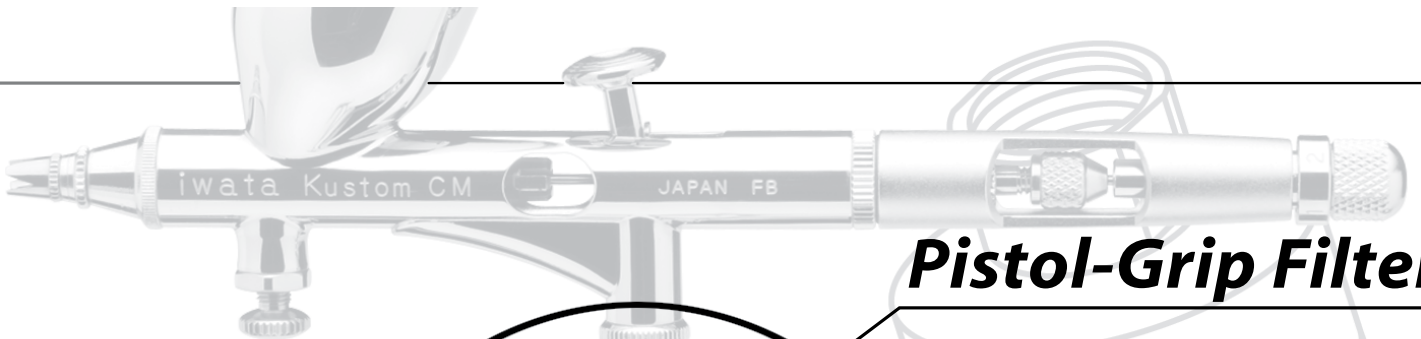

Pistol-Grip Filter

Every Iwata Kustom Series Airbrush features the Iwata-Medea Pistol-Grip Filter.



For clean, dry air-flow.
 Attaching directly onto the airbrush, the Iwata-Medea Pistol-Grip Filter is the final defense to deliver clean, dry air to your airbrush. Miniature in size, the super-fine, 5-micron filter element performs like a full-size moisture separator.
 The clear filter bowl allows a visual inspection of built-up moisture and is evacuated through a spring-loaded release valve – without taking the filter off the airbrush.
 Ergonomically designed, the Pistol-Grip Filter provides for many comfortable hours of spraying.



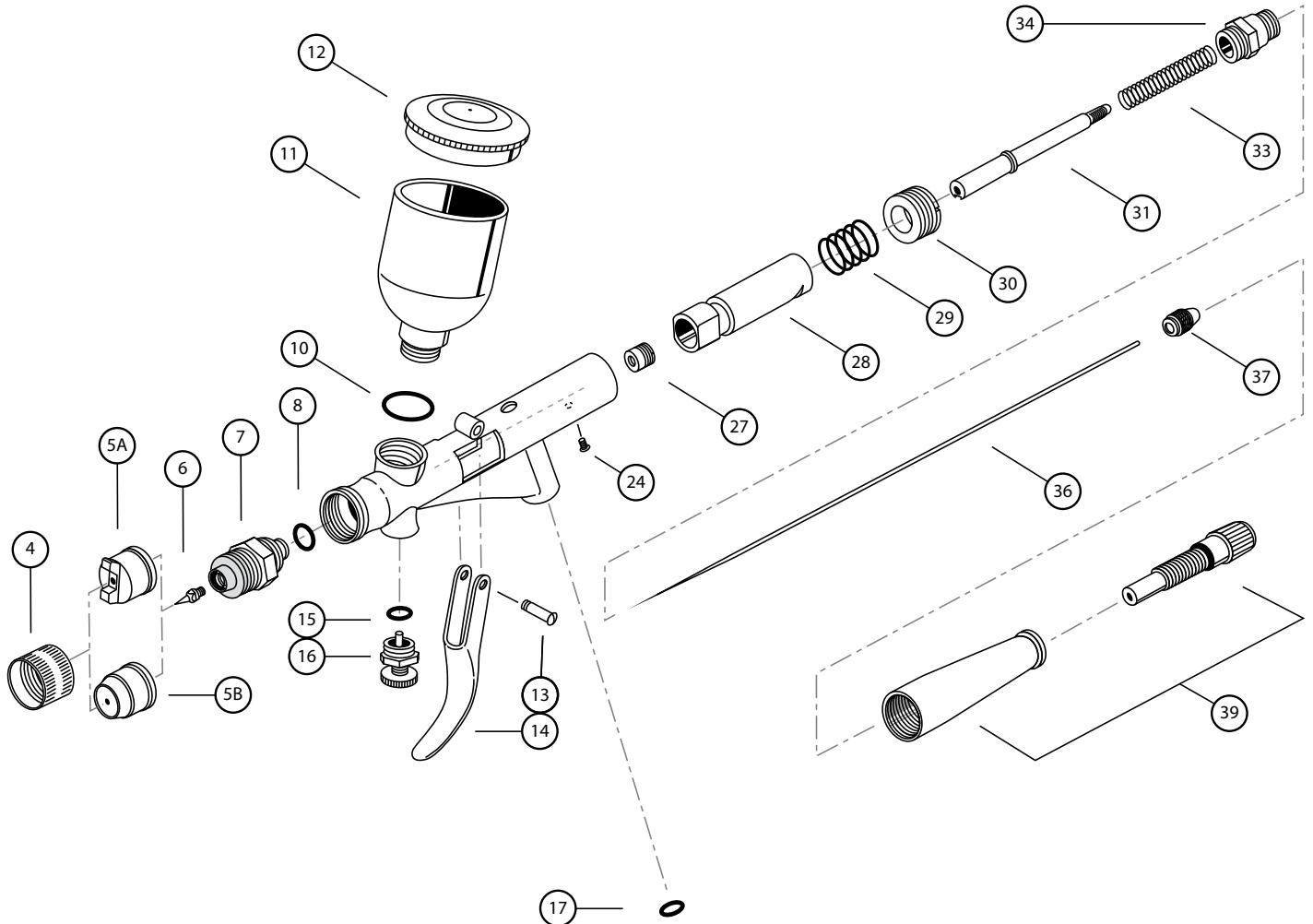

#	Code #	Part Name
4	I 110 7	Cover Ring
5A	I 110 5	Air Cap (Fan Pattern)
5B	I 110 6	Air Cap (Round Pattern)
6	I 081 1	Fluid Nozzle 0.50mm
7	I 082 1	Head Base
8	I 083 1	Packing Head Base
10	I 150 7	Packing Center Cup
11	I 070 8	Center Cup
12	I 718 2	Cup Lid
13	I 714 2	Trigger Screw
14	I 714 1	Trigger
15	I 190 2	Packing MAC Valve
16	I 190 1	Micro Air Control Valve
24	I 731 2	Main Body Ring Screw
27	I 125 8	Needle Packing Set
28	I 730 1	Slide Cam
29	I 730 2	Slide Cam Spring
30	I 731 1	Main Body Ring
31	I 715 2	Needle Chucking Guide
33	I 770 3	Spring
34	I 170 7	Spring Guide
36	I 075 7	Fluid Needle 0.50mm
37	I 120 1	Needle Chucking Nut
39	I 155 9	Pre-Set Handle

#	Code #	Part Name
17	I 145 1	Packing Air Valve
22	I 712 1	Air Valve Set
23	I 713 1	Air Valve
40	FA 450	Pistol Grip Filter
45	I 165 1	Spanner Wrench

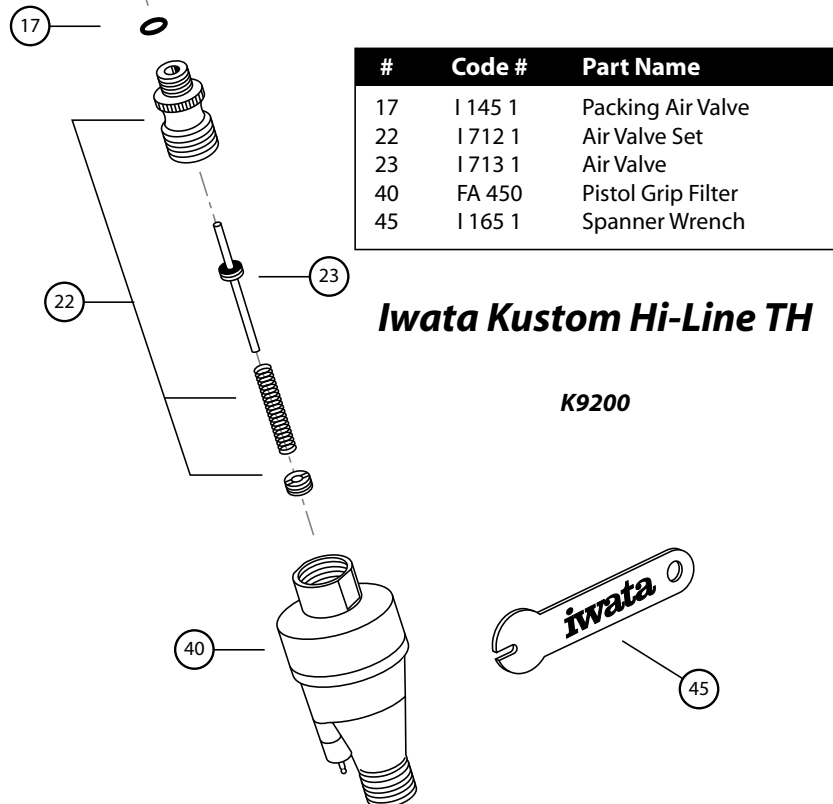

Iwata Kustom Hi-Line TH

K9200

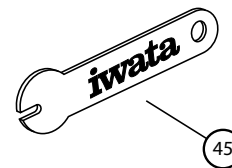

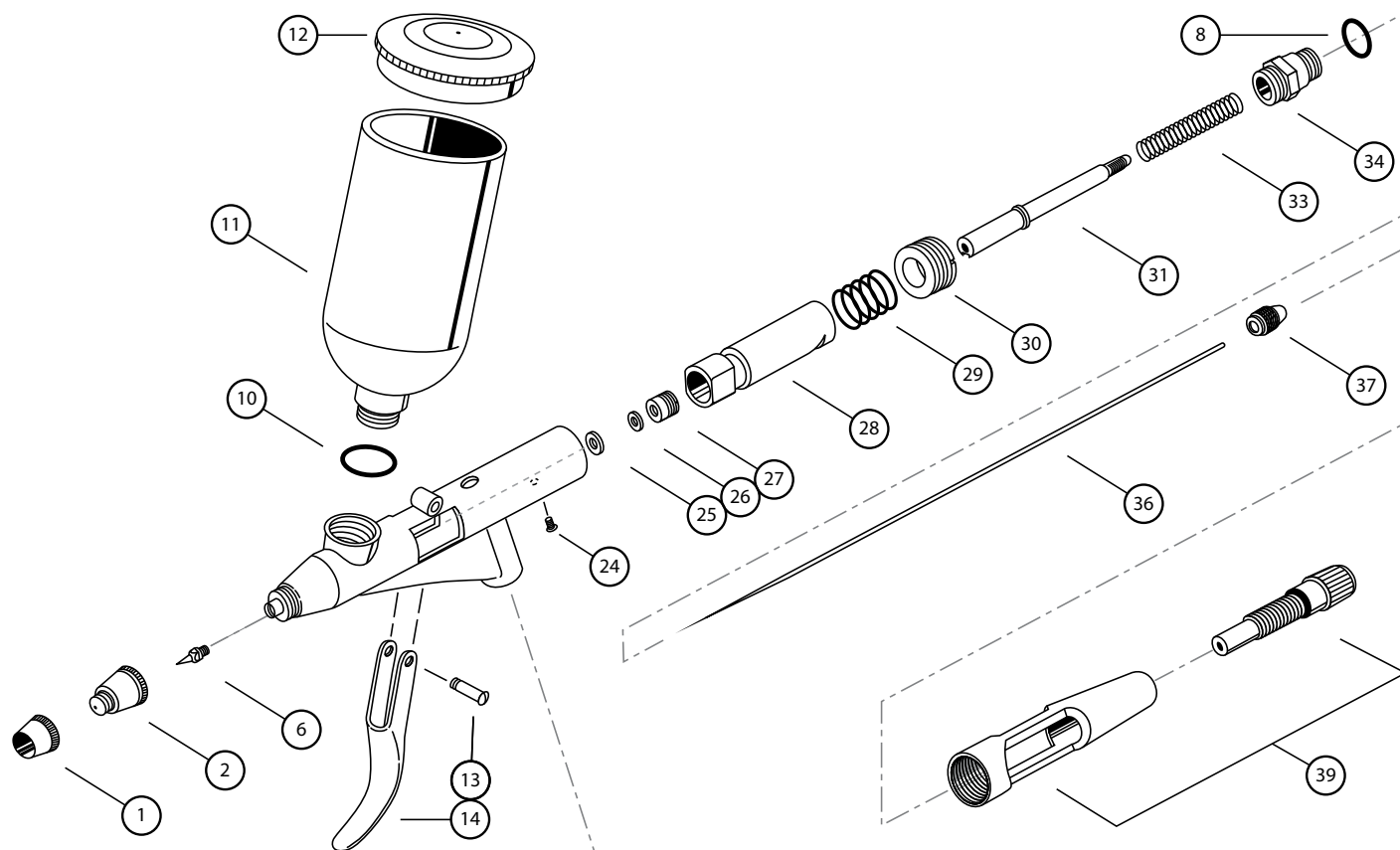

#	Code #	Part Name
1	I 701 3 I7011	Needle Cap
2	I 702 2	Nozzle Cap 0.30mm
6	I 704 2	Fluid Nozzle 0.30mm
8	I 605 1	Packing Head
10	I 150 7	Packing Center Cup
11	I 070 7	Center Cup
12	I 095 9	Cup Lid
13	I 714 2	Trigger Screw
14	I 714 1	Trigger
24	I 731 2	Main Body Ring Screw
25/27	+725-3 I7251	Teflon Needle Packing
26	I 150 2	Needle Packing
27	+725-2 I7251	Needle Packing Screw
28	I 730 1	Slide Cam
29	I 730 2	Slide Cam Spring
30	I 731 1	Main Body Ring
31	I 715 2	Needle Chucking Guide
33	I 770 3	Spring
34	I 170 7	Spring Guide
36	I 717 4	Fluid Needle 0.30mm
37	+120-1 I1202	Needle Chucking Nut
39	I 155 4	Pre-Set Cutaway Handle

#	Code #	Part Name
17	I 145 1	Packing Air Valve
22	I 712 1	Air Valve Set
23	I 713 1	Air Valve
40	FA 450	Pistol Grip Filter
45	I 165 1	Spanner Wrench

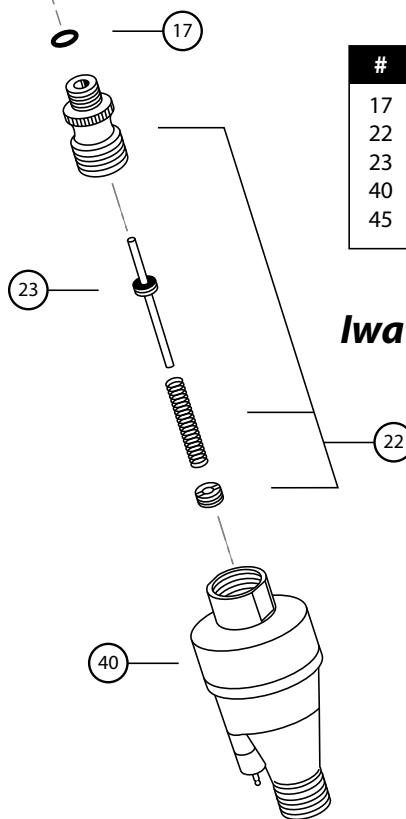

Iwata Kustom Revolution TR

K9400

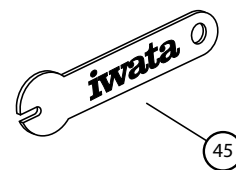

Parts Correction as of March, 2023

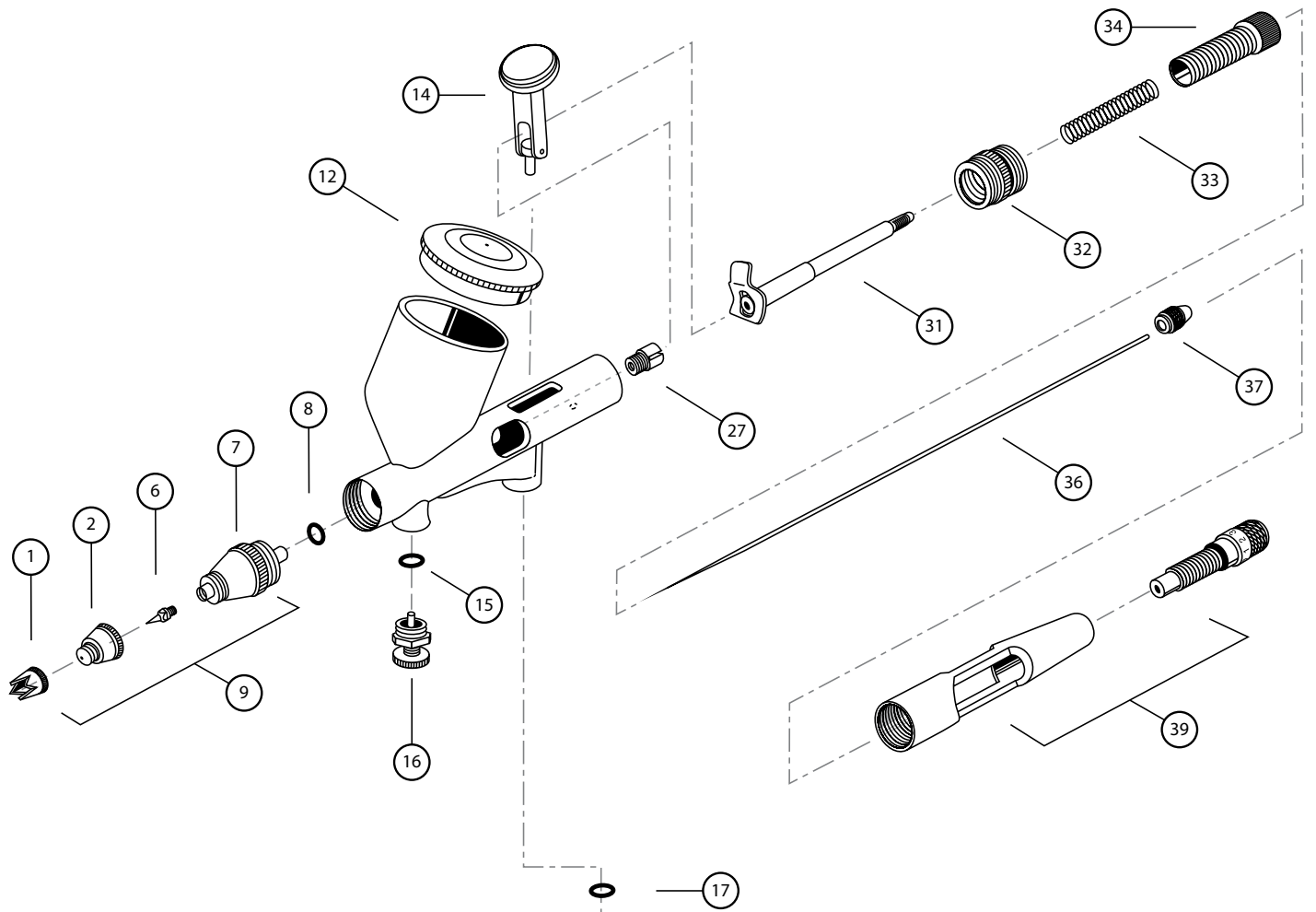

#	Code #	Part Name
1	I 535 1D	Needle Cap
2	I 535 2C	Nozzle Cap 0.23mm
6	I 535 2B	Fluid Nozzle 0.23mm
7	I 535 1A	Head System Base
8	I 580 2	Packing Fluid Head
9	I 535 2	Fluid Head System 0.23mm
12	I 718-1 I 6181	Cup Lid
14	I 545 3	Main Lever
15	I 190 2	Packing MAC Valve
16	I 190 1	Micro Air Control Valve
27	I 590 2	Needle Packing Set
31	I 115 7	Needle Chucking Guide with Auxiliary Lever
32	I 565 2	Spring Guide Screw
33	I 570 1	Spring
34	I 575 1	Needle Spring Adjuster
36	I 540 3	Fluid Needle 0.23mm
37	I 120-1 I 1202	Needle Chucking Nut
39	I 585 3	Pre-Set Cutaway Handle

#	Code #	Part Name
17	I 580 1	Packing Air Valve
22	I 510 1	Air Valve Set
40	FA 450	Pistol Grip Filter
45	I 165 1	Spanner Wrench

Iwata Kustom Micron CM

K9000

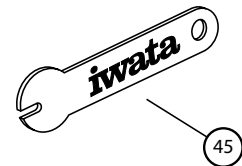

Parts Correction as of March, 2023

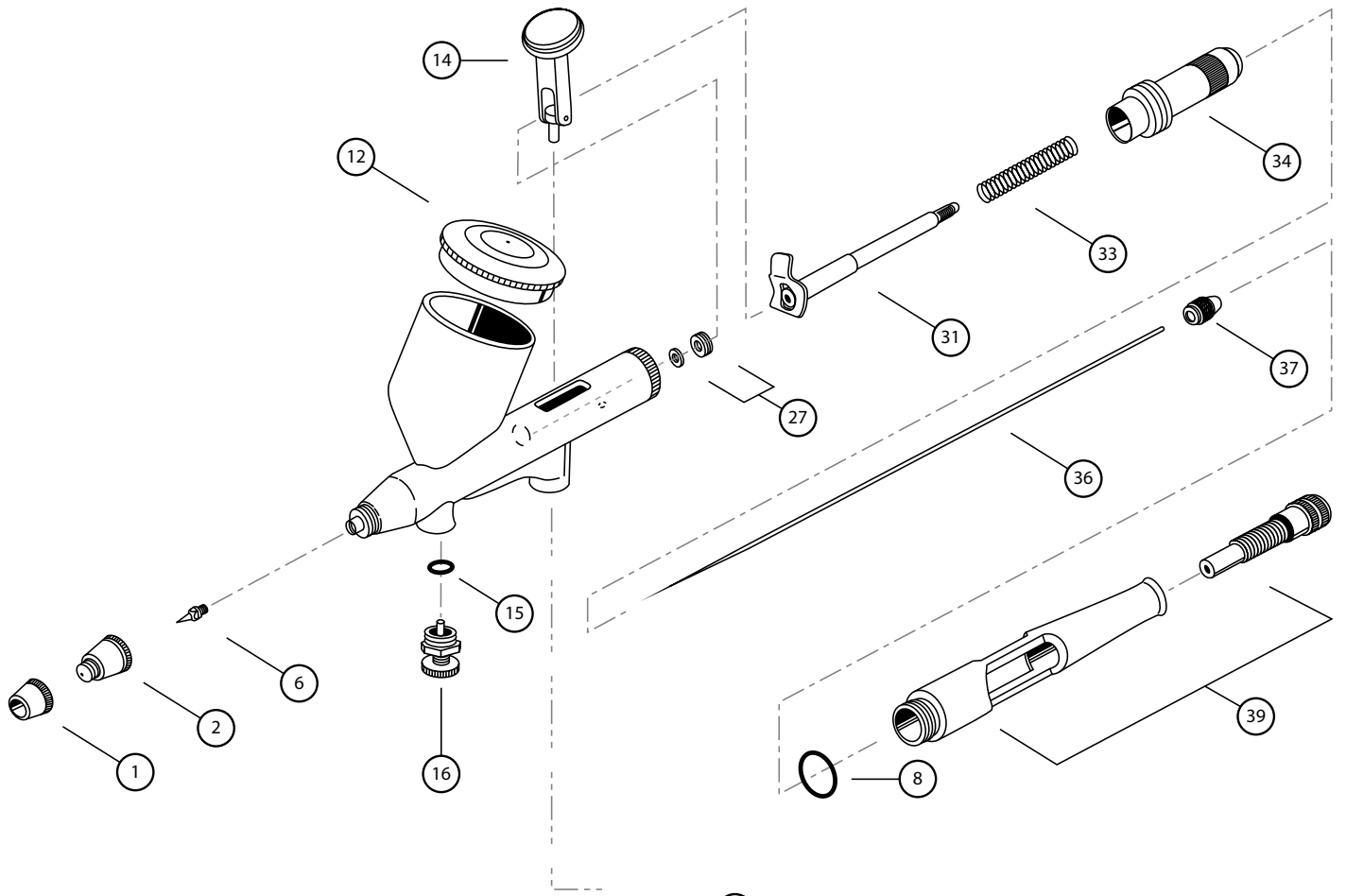

#	Code #	Part Name
1	I 110 2	Needle Cap
2	I 140 3	Nozzle Cap 0.30mm
6	I 080 8	Fluid Nozzle 0.30mm
8	I 605 1	Packing Head
12	I 718 1 I 6181	Cup Lid
14	I 545 3	Main Lever
15	I 190 2	Packing MAC Valve
16	I 190 1	Micro Air Control Valve
27	I 725 1	Needle Packing Set
31	I 715 1	Needle Chucking Guide
33	I 135 1	Spring
34	I 770 1	Spring Guide
36	I 075 3	Fluid Needle 0.30mm
37	I 120 1 I 1202	Needle Chucking Nut
39	I 155 6	Pre-Set Cutaway Handle

#	Code #	Part Name
17	I 145 1	Packing Air Valve
22	I 030 4	Air Valve Set
40	FA 450	Pistol Grip Filter
45	I 165 1	Spanner Wrench

Iwata Kustom Hi-Line CH

K9100

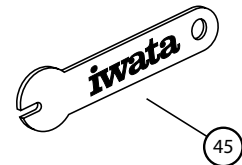

Parts Correction as of March, 2023

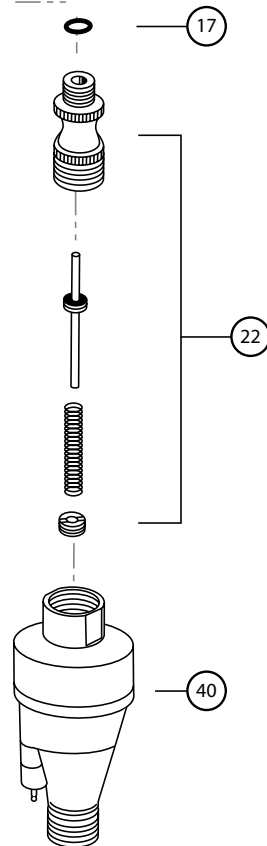

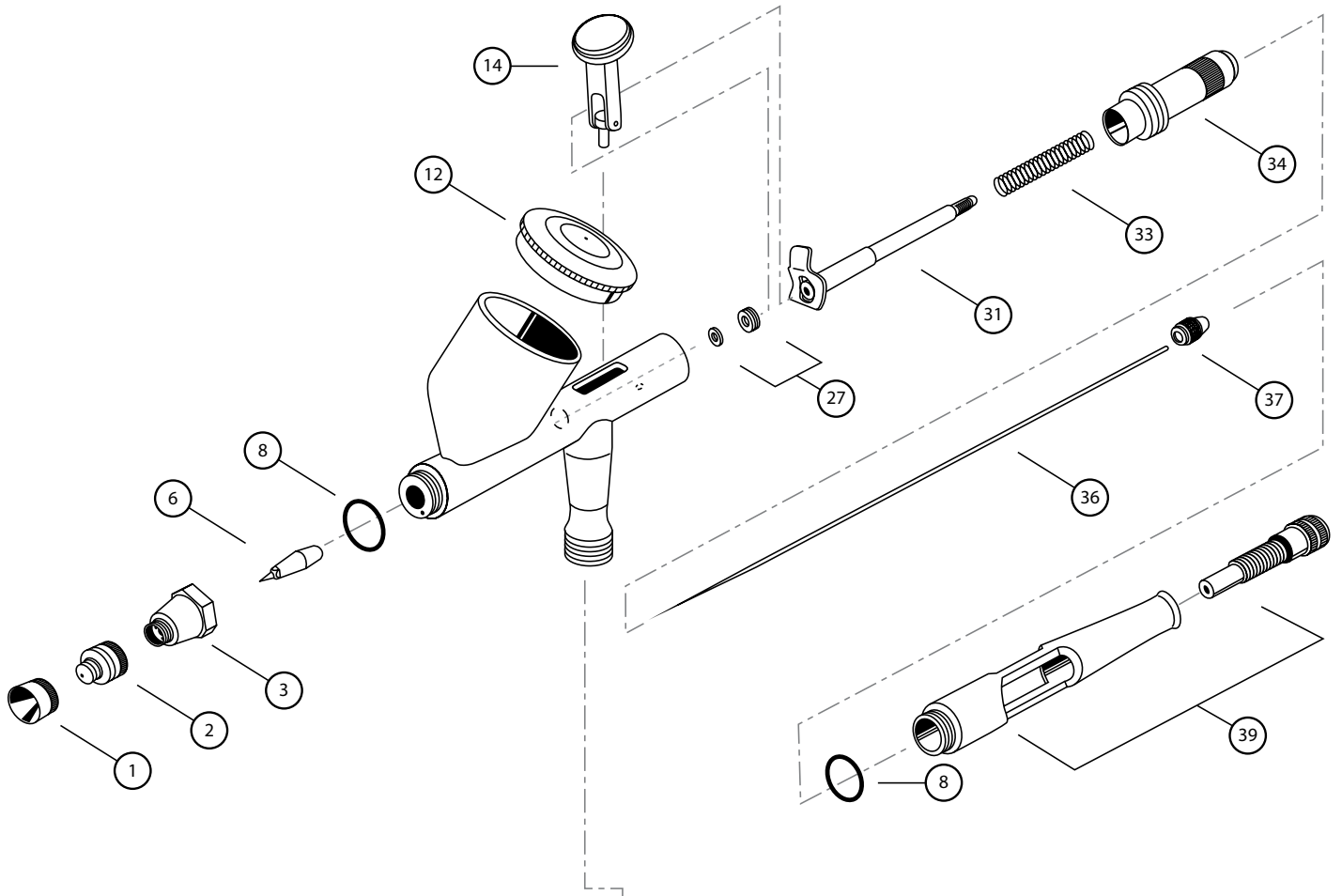

#	Code #	Part Name
1	I 601 1	Needle Cap
2	I 602 2	Nozzle Cap 0.35mm
3	I 603 1	Head Cap
6	I 604 2	Fluid Nozzle 0.35mm
8	I 605 1	Packing Head (Qty. 2)
12	I 618 1	Cup Lid
14	I 612 3 I 5453	Main Lever
27	I 725 1	Needle Packing Set
31	I 715 1	Needle Chucking Guide with Auxiliary Lever
33	I 135 1	Spring
34	I 770 1	Spring Guide
36	I 617 2	Fluid Needle 0.35mm
37	I 120 1 I 1202	Needle Chucking Nut
39	I 155 6	Pre-Set Cutaway Handle

#	Code #	Part Name
17	I 580 1	Packing Air Valve
18	I 608 1	Air Valve Guide Body
20	I 510 4	Air Valve Spring
21	I 611 1	Air Valve Guide
23	I 609 1	Air Valve
40	FA 450	Pistol Grip Filter
46	I 630 1	Spanner Head Cap Wrench

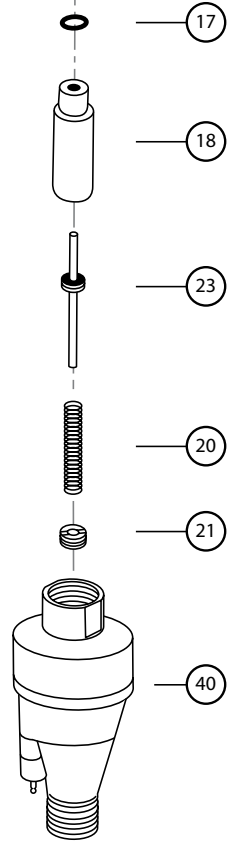

Iwata Kustom Eclipse CS

K9300

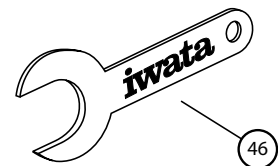

Parts Correction as of March, 2023

— IWATA KUSTOM SERIES AIRBRUSHES • MASTER PARTS LIST —

#	Code #	Part Name	TH	TR	CM	CH	CS
1	I 110 2	Needle Cap	x	x	x	■	x
1	I 535 1D	Needle Cap	x	x	■	x	x
1	I 601 1	Needle Cap	x	x	x	x	■
1	I 701 3 17011	Needle Cap	x	■	x	x	x
2	I 140 3	Nozzle Cap 0.30mm	x	x	x	■	x
2	I 535 2C	Nozzle Cap 0.23mm	x	x	■	x	x
2	I 602 2	Nozzle Cap 0.35mm	x	x	x	x	■
2	I 702 2	Nozzle Cap 0.30mm	x	■	x	x	x
3	I 603 1	Head Cap	x	x	x	x	■
4	I 110 7	Cover Ring	■	x	x	x	x
5A	I 110 5	Air Cap (Fan Pattern)	■	x	x	x	x
5B	I 110 6	Air Cap (Round Pattern)	■	x	x	x	x
6	I 080 8	Fluid Nozzle 0.30mm	x	x	x	■	x
6	I 081 1	Fluid Nozzle 0.50mm	■	x	x	x	x
6	I 535 2B	Fluid Nozzle 0.23mm	x	x	■	x	x
6	I 604 2	Fluid Nozzle 0.35mm	x	x	x	x	■
6	I 704 2	Fluid Nozzle 0.30mm	x	■	x	x	x
7	I 082 1	Head Base	■	x	x	x	x
7	I 535 1A	Head System Base	x	x	■	x	x
8	I 083 1	Packing Head Base	■	x	x	x	x
8	I 580 2	Packing Fluid Head	x	x	■	x	x
8	I 605 1	Packing Head	x	■	x	■	■
9	I 535 2	Fluid Head System 0.23mm	x	x	■	x	x
10	I 150 7	Packing Center Cup	■	■	x	x	x
11	I 070 7	Center Cup	x	■	x	x	x
11	I 070 8	Center Cup	■	x	x	x	x

#	Code #	Part Name	TH	TR	CM	CH	CS
12	I 095 9	Cup Lid	x	■	x	x	x
12	I 618 1	Cup Lid	x	x	x	x	■
12	I 718 1	Cup Lid	x	x	■	■	x
12	I 718 2	Cup Lid	■	x	x	x	x
13	I 714 2	Trigger Screw	■	■	x	x	x
14	I 545 3	Main Lever	x	x	■	■	x
14	I 612 3	Main Lever	x	x	x	x	■
14	I 714 1	Trigger	■	■	x	x	x
15	I 190 2	Packing MAC Valve	■	x	■	■	x
16	I 190 1	Micro Air Control Valve	■	x	■	■	x
17	I 145 1	Packing Air Valve	■	■	x	■	x
17	I 580 1	Packing Air Valve	x	x	■	x	■
18	I 608 1	Air Valve Guide Body	x	x	x	x	■
20	I 510 4	Air Valve Spring	x	x	x	x	■
21	I 611 1	Air Valve Guide	x	x	x	x	■
22	I 030 4	Air Valve Set	x	x	x	■	x
22	I 510 1	Air Valve Set	x	x	■	x	x
22	I 712 1	Air Valve Set	■	■	x	x	x
23	I 609 1	Air Valve	x	x	x	x	■
23	I 713 1	Air Valve	■	■	x	x	x
24	I 731 2	Main Body Ring Screw	■	■	x	x	x
25	I 725 3 17251	Teflon Needle Packing	x	■	x	x	x
26	I 150 2	Needle Packing	x	■	x	x	x
27	I 125 8	Needle Packing Set	■	x	x	x	x
27	I 590 2	Needle Packing Set	x	x	■	x	x
27	I 725 1	Needle Packing Set	x	x	x	■	■
27	I 725 2	Needle Packing Screw	x	■	x	x	x

#	Code #	Part Name	TH	TR	CM	CH	CS
28	I 730 1	Slide Cam	■	■	x	x	x
29	I 730 2	Slide Cam Spring	■	■	x	x	x
30	I 731 1	Main Body Ring	■	■	x	x	x
31	I 115 7	Needle Chucking Guide with Auxiliary Lever	x	x	■	x	x
31	I 715 1	Needle Chucking Guide	x	x	x	■	■
31	I 715 2	Needle Chucking Guide	■	■	x	x	x
32	I 565 2 15903	Spring Guide Screw	x	x	■	x	x
33	I 135 1	Spring	x	x	x	■	■
33	I 570 1	Spring	x	x	■	x	x
33	I 770 3	Spring	■	■	x	x	x
34	I 170 7	Spring Guide	■	■	x	x	x
34	I 575 1	Needle Spring Adjuster	x	x	■	x	x
34	I 770 1	Spring Guide	x	x	x	■	■
36	I 075 3	Fluid Needle 0.30mm	x	x	x	■	x
36	I 075 7	Fluid Needle 0.50mm	■	x	x	x	x
36	I 540 3	Fluid Needle 0.23mm	x	x	■	x	x
36	I 617 2	Fluid Needle 0.35mm	x	x	x	x	■
36	I 717 4	Fluid Needle 0.30mm	x	■	x	x	x
37	I 120 1 11202	Needle Chucking Nut	■	■	■	■	■
39	I 155 6	Pre-Set Cutaway Handle	x	x	x	■	■
39	I 155 4	Pre-Set Cutaway Handle	x	■	x	x	x
39	I 155 9	Pre-Set Handle	■	x	x	x	x
39	I 585 3	Pre-Set Cutaway Handle	x	x	■	x	x
40	FA 450	Pistol Grip Filter	■	■	■	■	■
45	I 165 1	Spanner Wrench	■	■	■	■	x
46	I 630 1	Spanner Head Cap Wrench	x	x	x	x	■

